

Material	Alterations	Mark	Date	Description	Appro.	Checked	Drawn	D. Yamada	Name:	Frame for Case
Heat Treatment										Drawing No.: 82S300C0
Hardness										
Plating										
Quantity	Unit	Scale	Date	Drawn	Checked	Approved			Cal. NO.:	82S3
	1/1000 mm	7:1							Parts No.:	
General Tolerances										
Dimensions										
Angles										

**MIYOTA**  
CITIZEN WATCH CO., LTD. TOKYO, JAPAN

This drawing is provisional and subject to our reconfirmation and/or revision without notice.

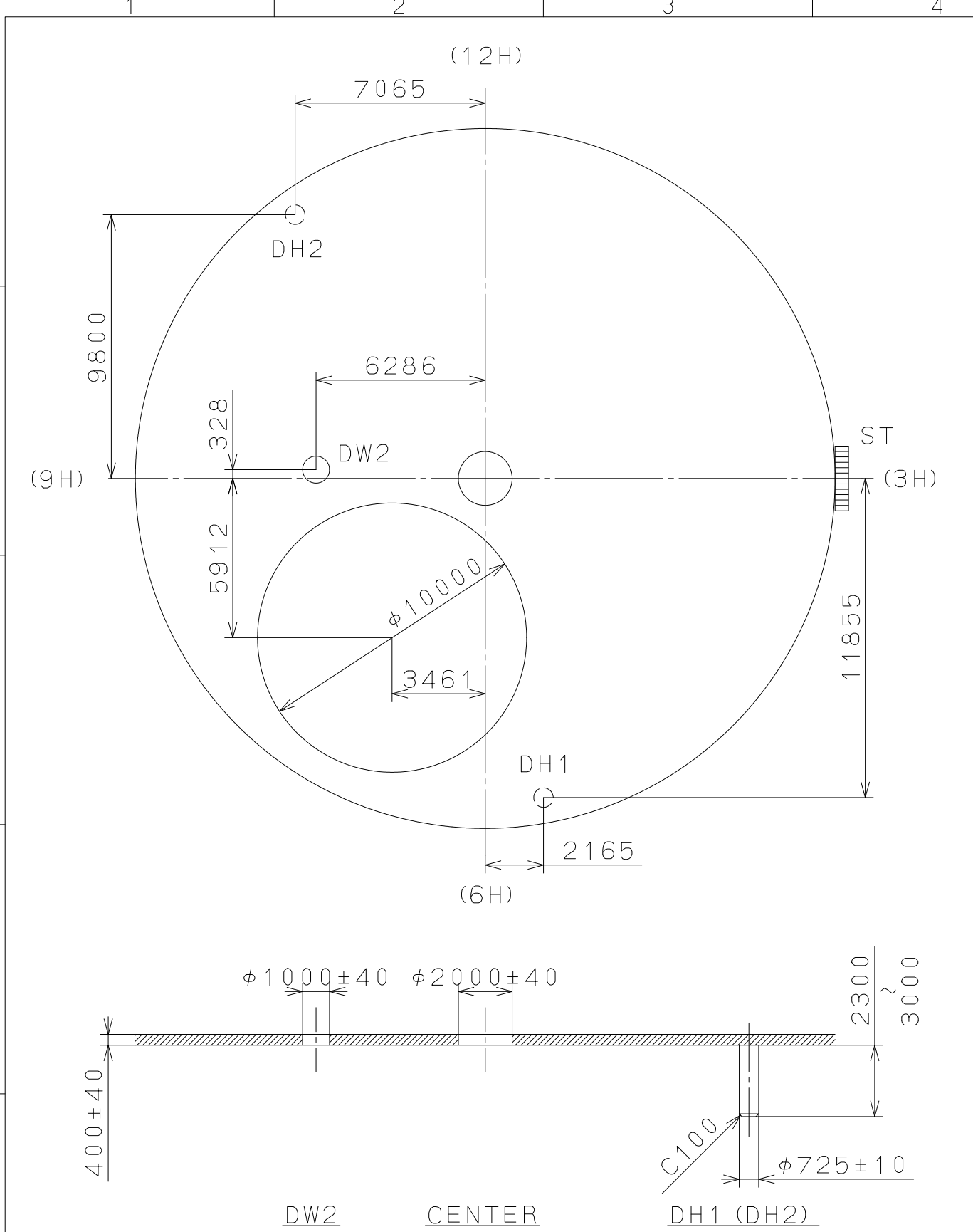

△			Quantity		Cal.NO.:
△			Unit	1/1000 <sub>mm</sub>	82S3-43A
△			Scale	5 : 1	Parts No.:
△			Date		
△			Drawn		
Mark	Date	Description	Appr.	Checked	Name:
		Alterations	Approved	D. Yamada	
Material					Indications for Dial
Heat Treatment					Drawing No.: 82S30ADS
Hardness					<b>MIYOTA</b>
Plating					

This drawing is provisional and subject to our reconfirmation and/or revision without notice.

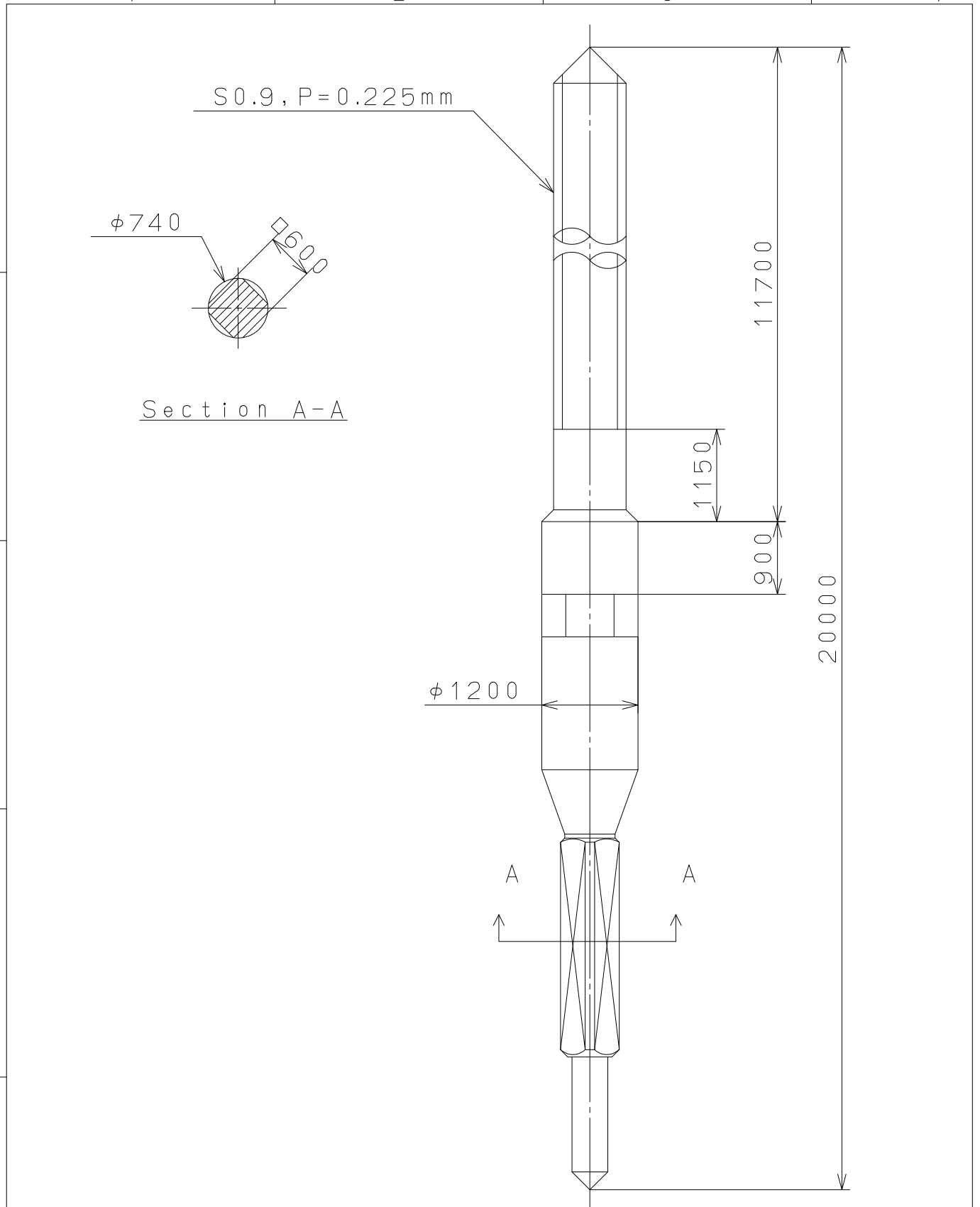

△5			Quantity		Cal.NO.:
△4			Unit	1/1000mm	
△3			Scale	15:1	Parts No.:
△2			Date		065-212
△1			Drawn		Name:
Mark	Date	Description	Appr.	Checked	D. Yamada
Alterations			Approved	SETTING STEM	
Material					Drawing No.: 212000S0
Heat Treatment					<b>MIYOTA</b> CITIZEN WATCH CO., LTD. TOKYO, JAPAN
Hardness	General Tolerances				
Plating	Dimensions				
	Angles				

This drawing is provisional and subject to our reconfirmation and/or revision without notice.

F E D C B A

1 2 3 4 5 6 7 8

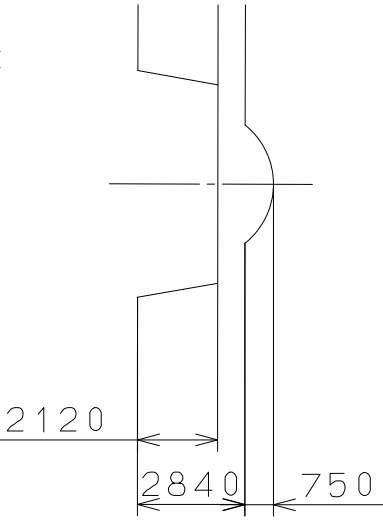
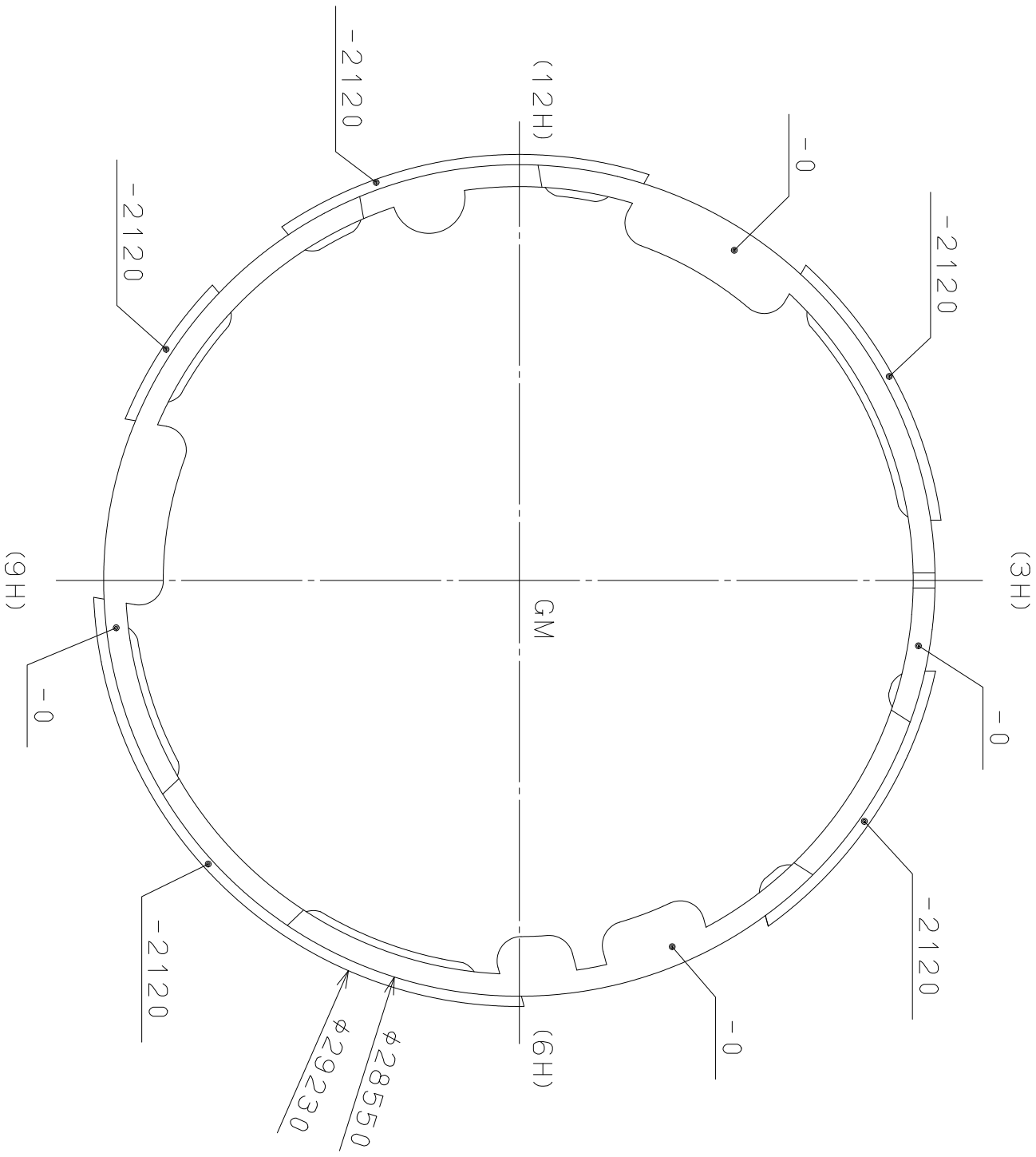

View CC-CC  
DD-DD, EE-EE

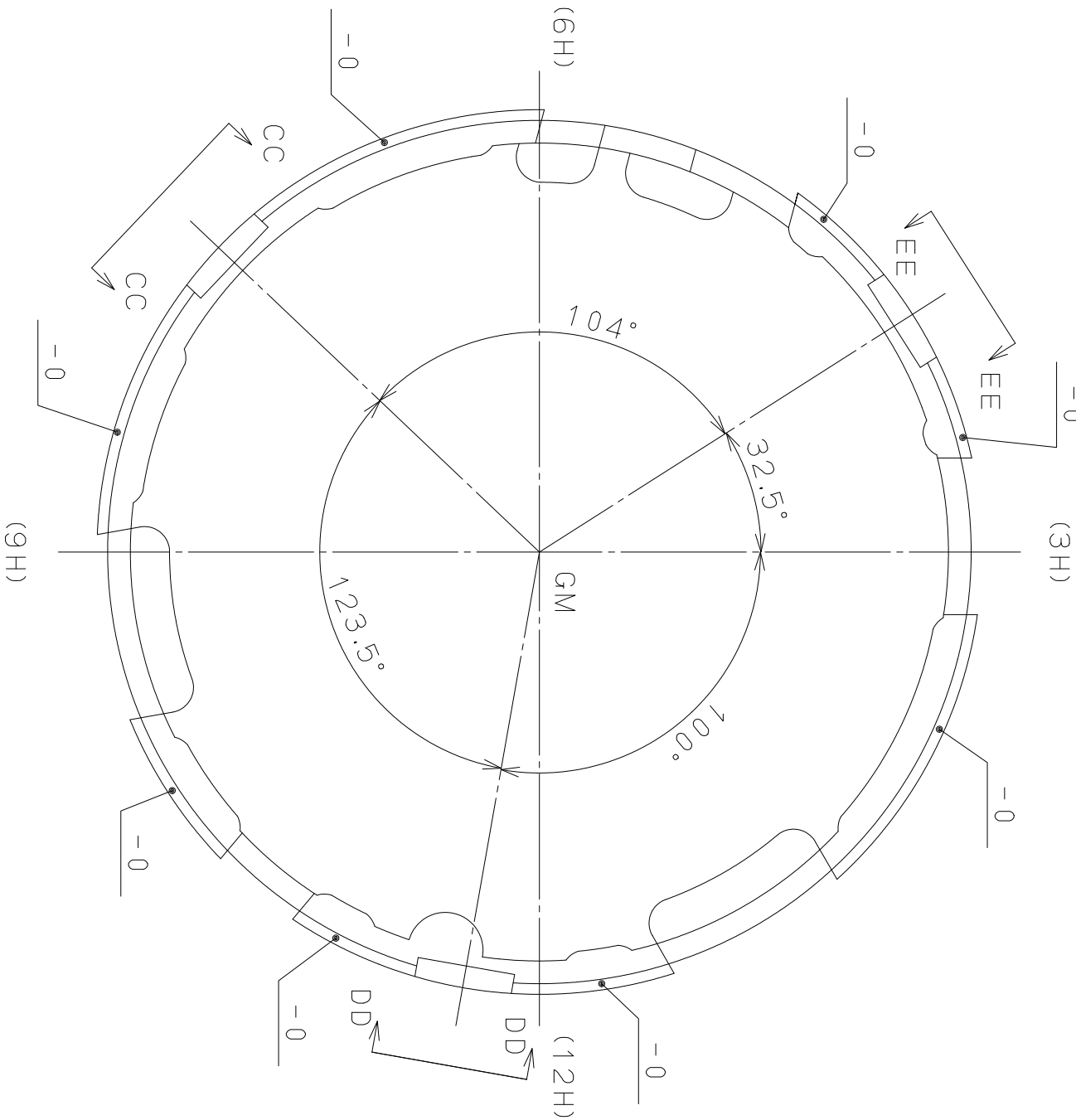

Quantity	Unit	1 / 1000 mm	Cal. NO. :
Scale	Scale	5 : 1	Parts No. :
Date	Date	500-710	
Date	Drawn		
Alterations		Approved	Name :
Date	Description	Checked	Casing Holder
		Approved	D. Yamada
Material		General Tolerances	Drawing No. : 820500E0
Heat Treatment		Dimensions	<b>Miyota</b>
Hardness		Angles	
Plating		Angles	
		Angles	CITIZEN WATCH CO., LTD. TOKYO, JAPAN