

This drawing is provisional and subject to our reconfirmation and/or revision without notice.

DH1~DH2=16171 (±20)

Coordinates

Mark	X	Y	R
GM	0	0	—
DH1	-7900	-3000	—
DH2	8234	-1900	—
a1	-7569	-3828	300
a2	-7252	-4215	200
a3	-5914	-5092	200
a4	-5433	-5228	300
a5	4625	-5757	300
a6	5106	-5621	200
a7	6444	-4745	200
a8	6761	-4358	300
a9	4947	5546	300
a10	4628	6054	300
a11	2754	7083	300
a12	2157	7026	300

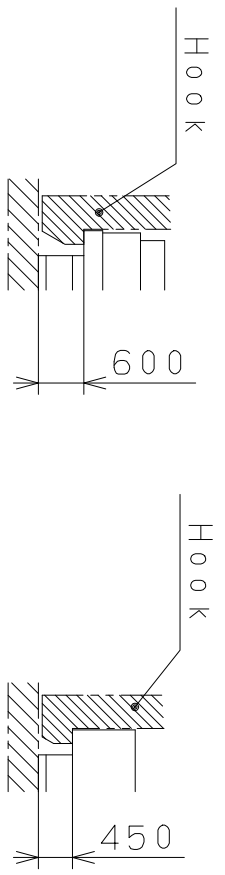
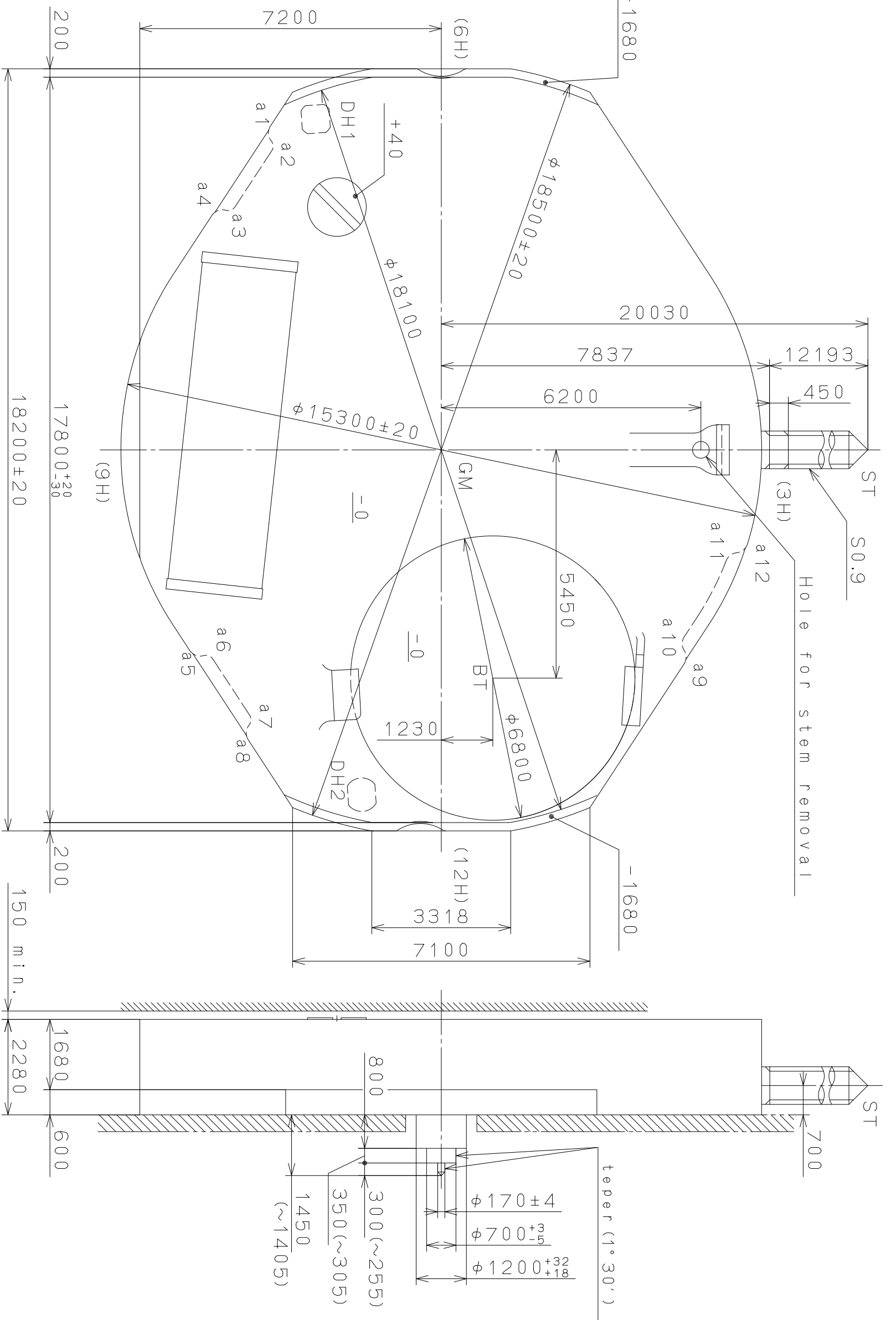

Section a1~a4, a5~a8

Section a9~a12

Material	Alterations	Date	Description	Appr.	Checked	Drawn	Name:
Heat Treatment							Frame for Case
Hardness							Drawing No.: GL30C001
Plating							
Quantity	Unit	Scale	Date	Drawn	Checked	Drawn	Name:
1	1/1000 mm	10:1					Frame for Case
Cal. NO.:	GL30	Parts No.:					
MIYOTA							
CITIZEN WATCH CO., LTD. TOKYO, JAPAN							

This drawing is provisional and subject to our reconfirmation and/or revision without notice.

*** T I P W (01) *** (2100 1121) 03-06-02

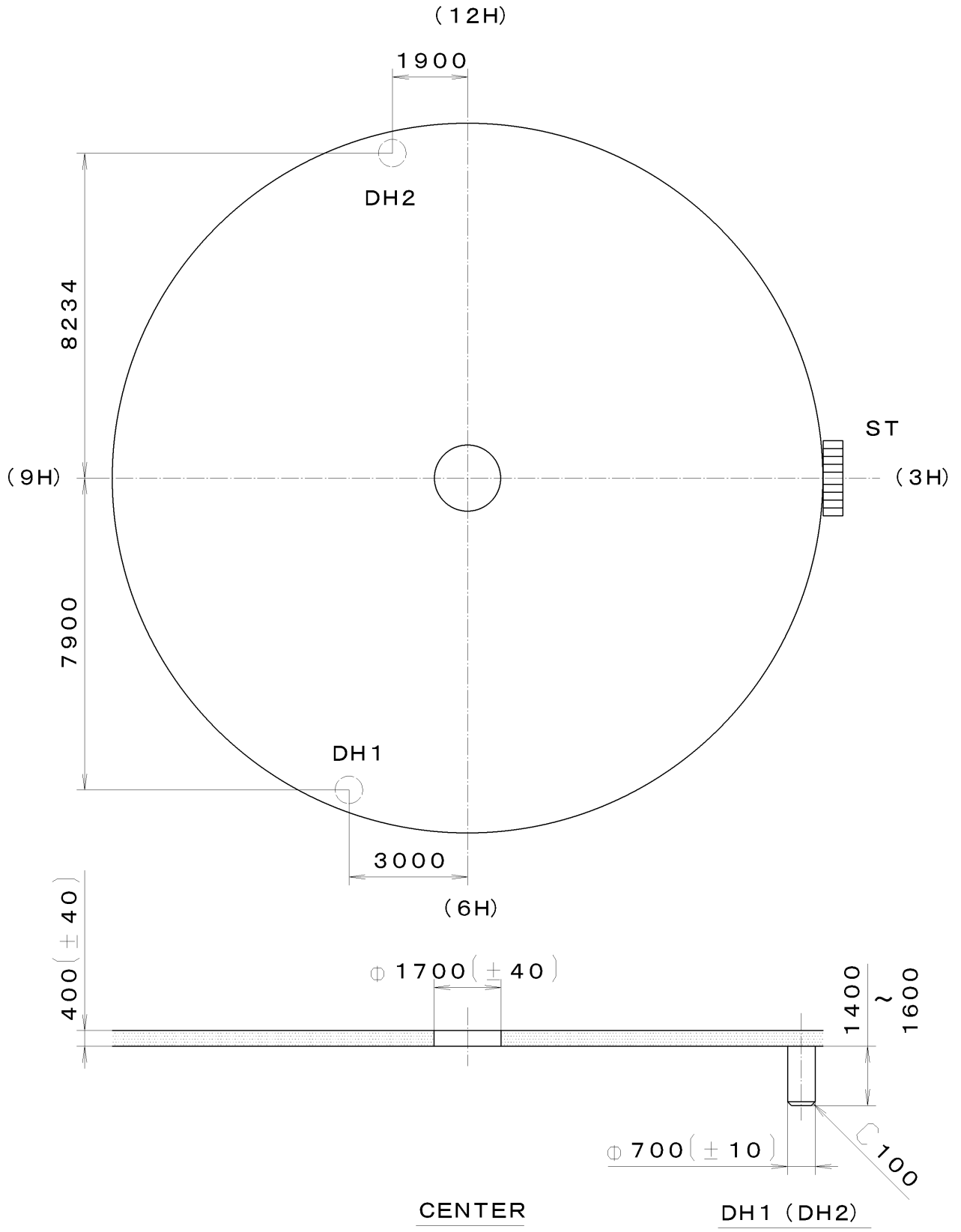

△7			Quantity		Cal. No. :	GL30-00A
△6			Unit	1/1000 mm	Name:	
△5			Scale	7:1	Indications for Dial	
△4			Date		Drawing No. : GL30D000	
△3			Drawn		<div style="text-align: center;">MIYOTA</div> CITIZEN WATCH CO., LTD. TOKYO, JAPAN	
△2			Checked	M. Fukuda		
△1			Approved			
Material			General Tolerances			
Heat Treatment			Dimensions			
Hardness			Angles			
Plating						

This drawing is provisional and subject to our reconfirmation and/or revision without notice.

*** T I P W 065-541 (01) *** (2100 1121) 02-07-12

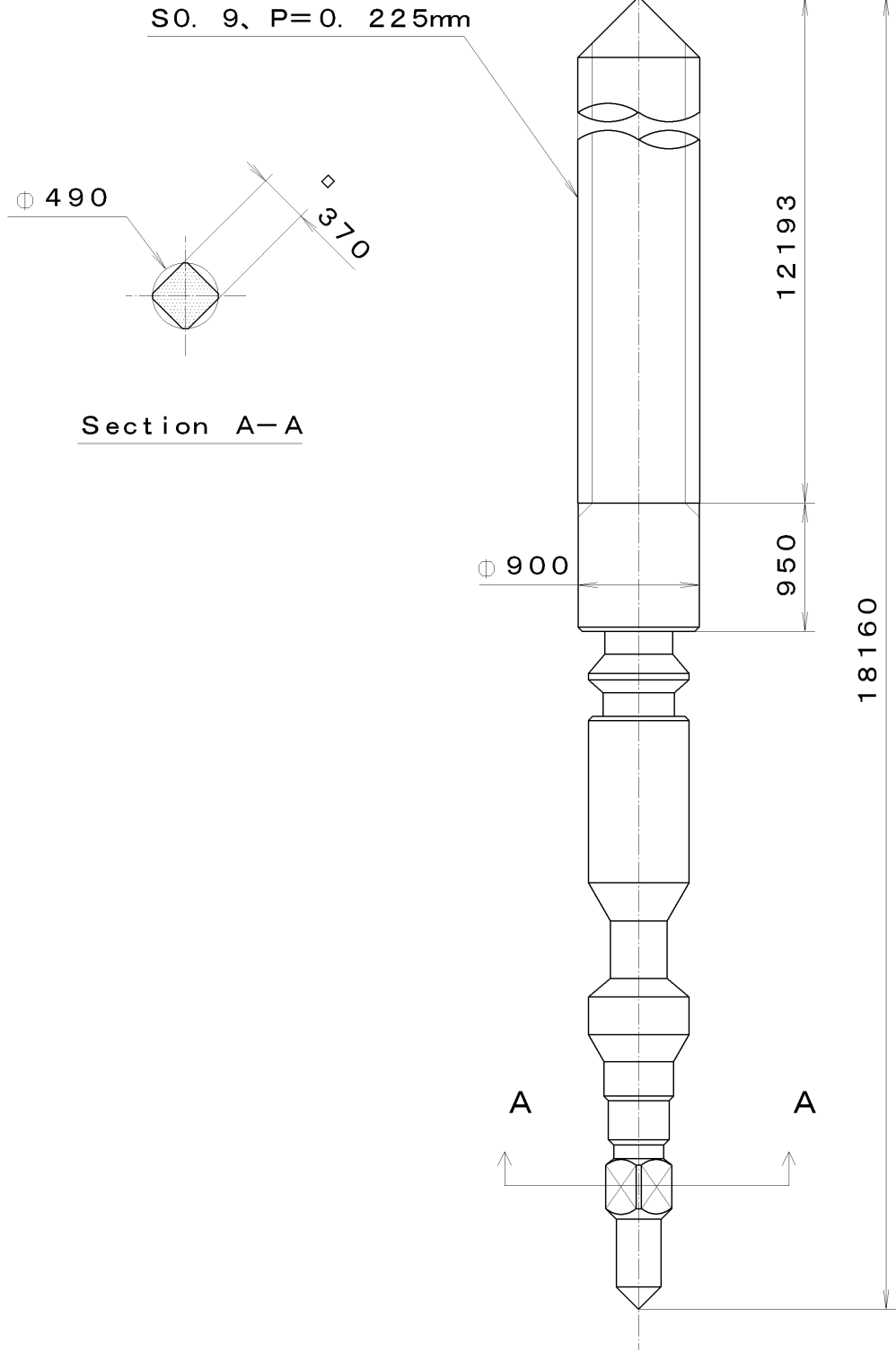

7			Quantity		Cal. No. :
6			Unit	1/1000 mm	
5			Scale	20:1	Parts:
4			Date		065-541
3			Drawn		
2			Checked	T. Hiruta	Name:
1			Approved		SETTING STEM
Material					Drawing No. : 5410S000
Heat Treatment			General Tolerances		MIYOTA CITIZEN WATCH CO.,LTD. TOKYO,JAPAN
Hardness			Dimensions		
Plating			Angles		